

CAMBRIDGE ELEVATING INC.

PREMIER MANUFACTURER OF CUSTOM ELEVATORS

JOURNEY LULA Design Guide

(Limited-Use/Limited-Application)



Sales | Service | Installation

1261 Industrial Road | Cambridge, Ontario | N3H 4W3 | 1.800.265.3579

Introduction

The Cambridge Elevating Limited-Use/Limited-Application Elevator is designed to service schools, libraries, low rise, low occupancy commercial buildings, churches and multi-family housing. It provides the functionality of a commercial elevator with the elegance of a residential elevator.

This design guide will assist architects, general contractors and elevator professionals in the planning for a Cambridge Elevating LU/LA installation in accordance with ASME A17.1 and CAN/CSA B44.

Please note all dimensions and specifications contained herein are nominal and should only be used in the early planning stages. Construction of the actual hoistway and related LU/LA requirements should be based on job-specific application drawings.

Disclaimer

All drawings within this guide are not to be disclosed or reproduced in any manner without the express written permission of Cambridge Elevating Inc.

Cambridge Elevating Inc. reserves the right to alter minimum/maximum tolerances in all matters due to engineering concerns or advancements.

Table of contents

1.1 LU/LA Specifications	2
1.1 Provisions by Others	3
2.1 Hoistway Layout – Concrete Wall	4
2.2 Hoistway Layout – Typical Rail Loads	5
2.3 Hoistway Layout – Minimum Overhead	6
3.1 Pit Details	7
4.1 Machine Room Details – General Layout	8
5.1 Two Speed Hoistway/Cab Door Details	9
6.1 Standard Car Layout – Inline Configuration	10
6.2 Standard Car Layout – Through Configuration	11
6.3 Standard Car Layout – 90 Degree Configuration	12

1.1 LU/LA Specifications

Drive System

2:1 Roped hydraulic drive system

Features

Up to 25 ft. of Travel (Except Ontario and various US States, check local code)

1400 lbs. (635 kg) Capacity

30 fpm (0.15 m/s)

14" Minimum Pit Required (Ladder required for 35" and up)

11'-6" Minimum Overhead (Standard refuge space)

9'-2" Minimum Overhead (with the use of overhead refuge prop) if allowed by local Code

Cab Appointments

Inline, through, 90 degree side access configurations available

Up to 18 sq/ft maximum

86" interior Cab Height (Nominal)

Specifications

3-1/2" (90mm) Hydraulic Cylinder

2 x 3/8" diameter steel rope, 7x19 Construction, Breaking Load - 14388 lbs (64.01kN)

Controller; Single Automatic Microprocessor (Selective Collective available)

5 HP, 220V/1/60Hz drive motor with submersible screw pump (208V & 600V 3-phase 60Hz optional)

Manual lowering device on power unit

Battery back-up for emergency lowering, lighting, alarm bell and door opening

Relay logic controller for ease of service with tape reader selector

Beige epoxy finished 2-Speed automatic horizontally sliding doors on cab and landings with 36" (915mm) openings

Full height infra-red safety light curtain for added passenger safety at door opening

Automatic operation, automatic re-leveling, automatic lighting

Black powder coated steel car frame with raised plastic laminate fire-rated panels

Black powder coated steel car ceiling with recessed LED lighting (4)

Stainless steel car control panel with LED illuminated push buttons and Digital Position Indicator (DPI)

Stainless steel handrail, recessed lighting bezels and LED illuminated hall call stations

Options

Stainless steel finished 2-Speed automatic horizontally sliding doors on cab and landings with 36" (915mm) openings

Optional raised plastic laminate fire-rated panels

In car directional lanterns in elevator car strike post

Stainless steel call stations with Digital Position Indicator (DPI) display

Stainless license/certificate frame

1.2 Provisions by Others

1. Finished hoistway plumb within ½ inch from top to bottom, and conforming to the dimensions indicated on the layout drawings provided. All walls and side members must be square and extend from pit floor to the ceiling of the shaft. Inside surface of the hoistway must be flush. Interior of hoistway and doors should be finished prior to the installation of the lift. Hoistway must be constructed in accordance with CSA B44 or ASME A17.1 and all Provincial/State and local building code requirements.
2. Adequate supports shall be provided for fastening rail brackets as indicated on the layout drawings. Supports must withstand rail forces indicated. The elevator contractor is not responsible for the structural design of the building and its ability to support the elevator loads and/or reactions.
3. Where wood frame construction is used, 2"x6" with inserts spaced as indicated on the layout drawings, and extending the full height of the hoistway are recommended. Please consult the project architect for design specifications.
4. For masonry walls, inserts shall be provided by the elevator contractor and installed by the general contractor.
5. Total travel distance from finished bottom floor to finished top floor must be held within 1" of that shown on the layout drawings.
6. Overhead clearance: (Top floor to underside of hoistway ceiling or obstruction) to be maintained per the layout drawings. If any of the hoistway dimensions cannot be achieved, contact the factory for alternate arrangements.
7. A poured pit conforming to the dimensions indicated on the layout drawings must be provided. The pit must be designed for the impact load indicated and must be dry and level from wall to wall.
8. A sump pump is NOT necessary unless required by local code. Where water seepage is encountered a sump pump and sump pump hole with cover is recommended in the elevator pit. A G.F.I. receptacle is required. If a sump pump is furnished, coordinate location with the elevator contractor.
9. A pit light with switch to be provided and installed.
10. All screens, railings, steps, and ladders as required for a legal hoistway.
11. Barricades outside all hoistway openings for protection shall be provided and installed by the general contractors.
12. Clearance between hoistway door and sill must not exceed 3", nor 5" between hoistway door and car gate per CSA B44 or ASME A17.1.
13. All wall patching, painting, and grouting by others.
14. An adjacent machine room built to conform to the layout drawings, C.E.C. or N.E.C., CSA B44 or ASME A17.1, and all Provincial/State and local code requirements. It shall have suitable access, a self closing/self locking door, a convenience outlet, and light switch. Machine room temperature must be maintained between 60 and 90 degrees Fahrenheit. Relative humidity not to exceed 95%. HVAC or venting may be required. All venting to meet local fire code.
15. A 220V, single phase, (40 AMP at 5 Hp) service, with neutral, to a lockable safety disconnect switch fused with time delay fuses (40 AMP) shall be furnished in the machine room in accordance with C.E.C. or N.E.C. A normally open electrical interlock contact is required in the switch for battery isolation. Optional 208V/3/60 and 600/3/60 service available.
16. A 120VAC, single phase, 15 AMP service to a lockable, fused, disconnect switch or circuit breaker located in the machine room shall be provided for the cab lighting in accordance with C.E.C. or N.E.C.
17. A separate (dedicated) telephone line to the machine room and tied into the elevator controller per CSA B44 or ASME A17.1. Telephone must be monitored by a live service 24hrs, 7 days/week by authorized personnel.
18. Contractor shall provide conduit and ducting between the machine room and elevator hoistway for routing of hydraulic and electrical lines. Location and route to be coordinated with elevator contractor.

2.1 Hoistway Layout – Concrete Wall

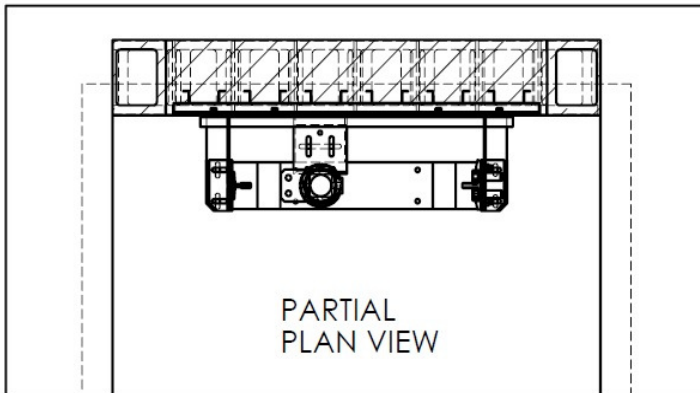
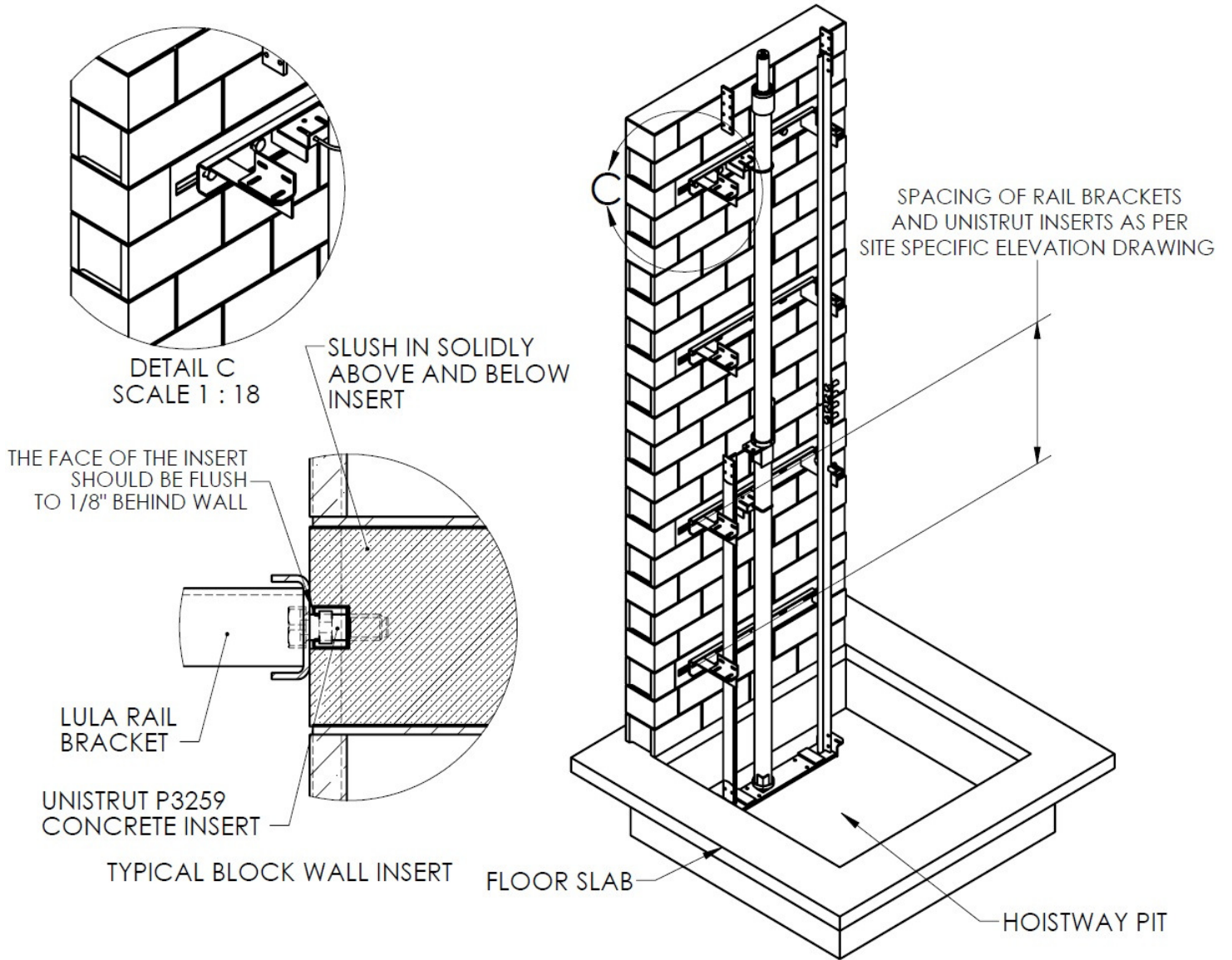

CAMBRIDGE ELEVATING IS NOT RESPONSIBLE FOR THE STRUCTURAL DESIGN OF THE BUILDING AND ITS ABILITY TO SUPPORT THE ELEVATOR LOADS AND/OR REACTIONS

2.2 Hoistway Layout – Typical Rail Loads

RAIL REACTIONS	
R1	700lbf 3.11kN
R2	225lbf 1.0kN
R3	700lbf 3.11kN

RAIL REACTIONS DO NOT
INCLUDE SAFETY FACTOR

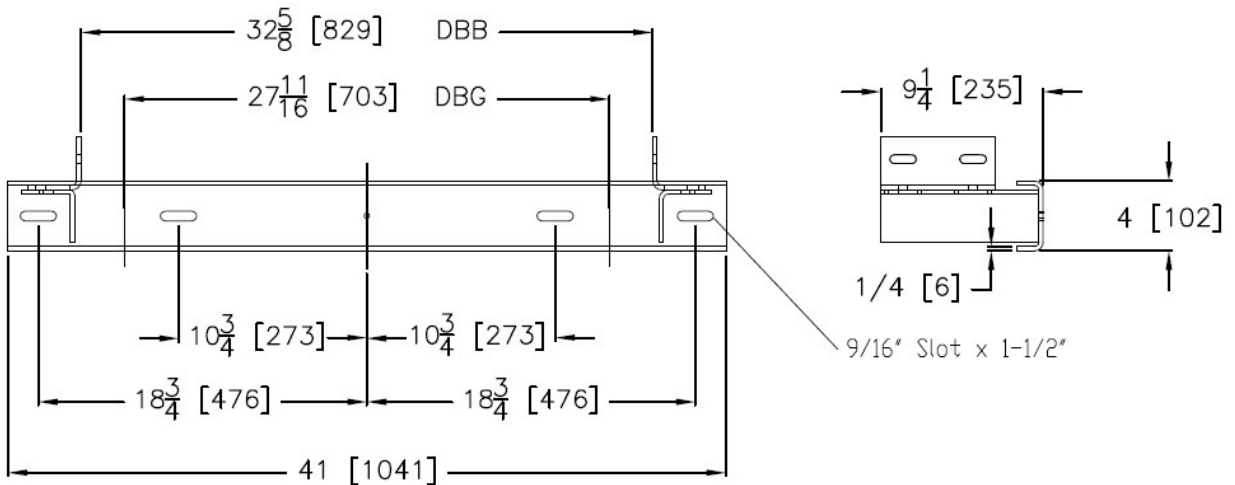
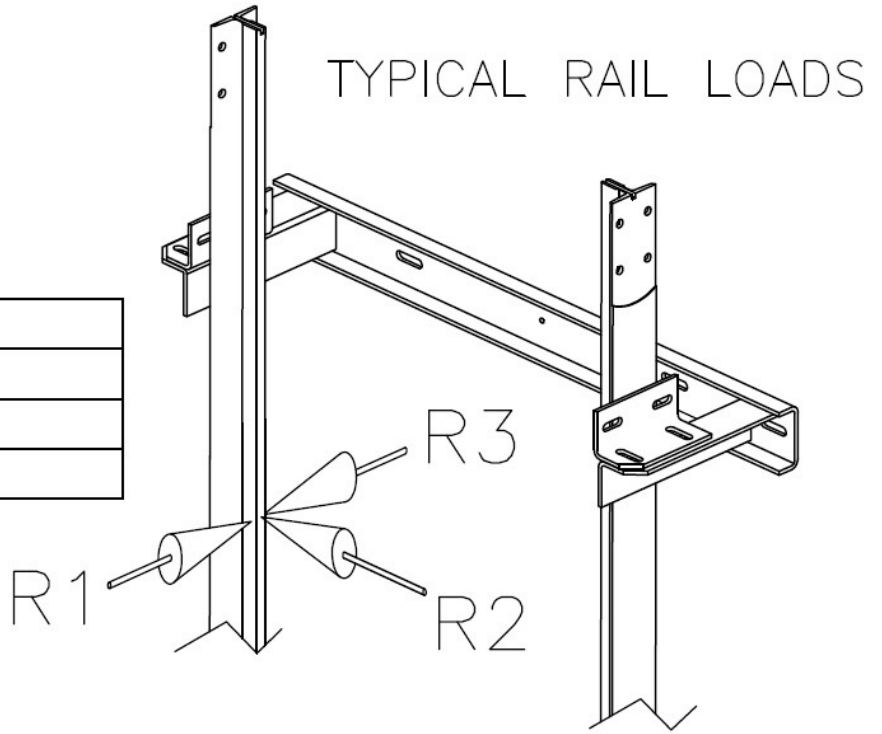

2.3 Hoistway Layout – Minimum Overhead

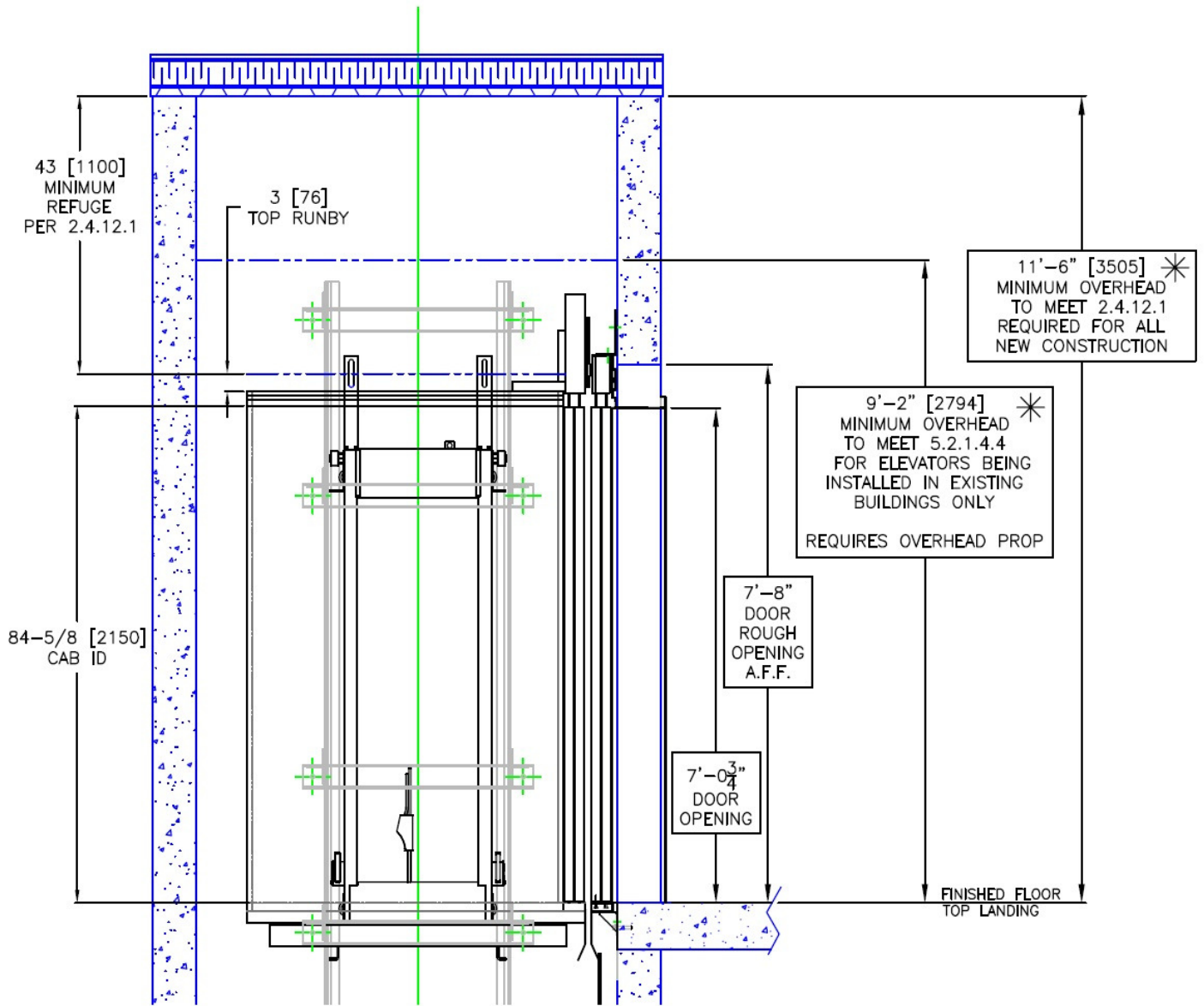

* NOTE – ONTARIO ELEVATING AND AMUSEMENT DEVICES SAFETY DIVISION CODE ADOPTION DOCUMENT #250/1 (1NOV2011) PERMITS ALL LULA ELEVATORS IN ONTARIO TO MEET 5.2.1.4.4 BY UTILIZING OVERHEAD PROPS TO PROVIDE REFUGE, REGARDLESS IF NEW OR EXISTING BUILDING. AT LEAST 120" IS PREFERRED – 110" IS ABSOLUTE MINIMUM. THERE IS AN EXTRA CHARGE FOR ELEVATORS REQUIRING AN OVERHEAD PROP.

OTHER JURISDICTIONS SHOULD CHECK WITH THEIR A.H.J. TO CONFIRM MINIMUM REFUGE REQUIREMENTS

3.1 Pit Details

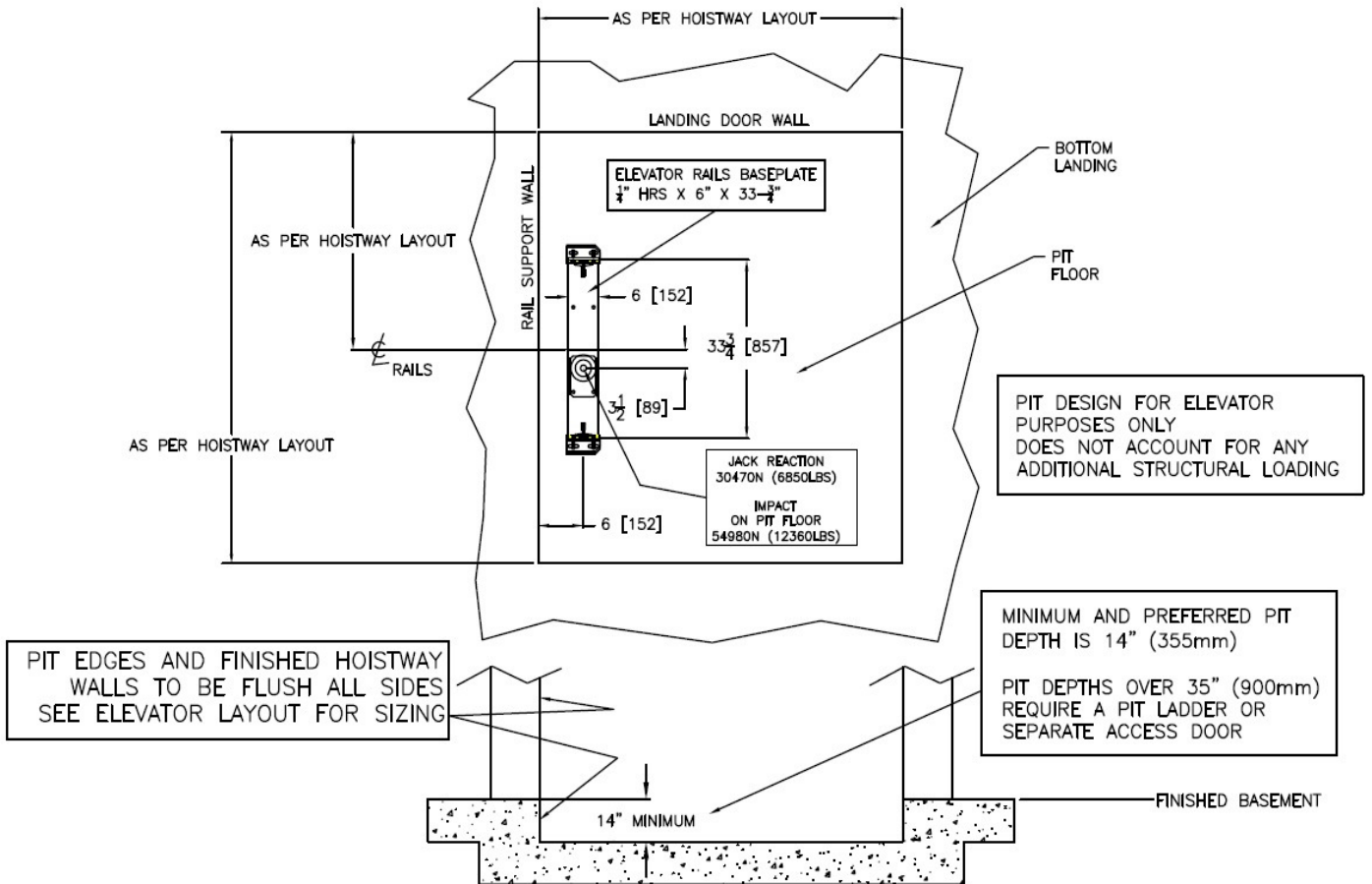

PIT DESIGNS SHOULD BE APPROVED BY A LICENSED STRUCTURAL ENGINEER

Suggested hoistway pit floor construction consists of a concrete slab (thickness to be determined by general contractor's structural engineer) poured on a natural or compacted soil with a minimum allowable bearing pressure of 1.0 KSF. The minimum compressive strength of the concrete at 28 days must be no less than 20 MPa. #5 reinforcing steel (grade 60) must be placed at the bottom of the slab in 2 traverse directions and at a spacing of 12" (305 mm). Hoistway pit floor to support a load of 13 kips (13,000 lbs)/58KN (includes impact).

4.1 Machine Room Details – General Layout

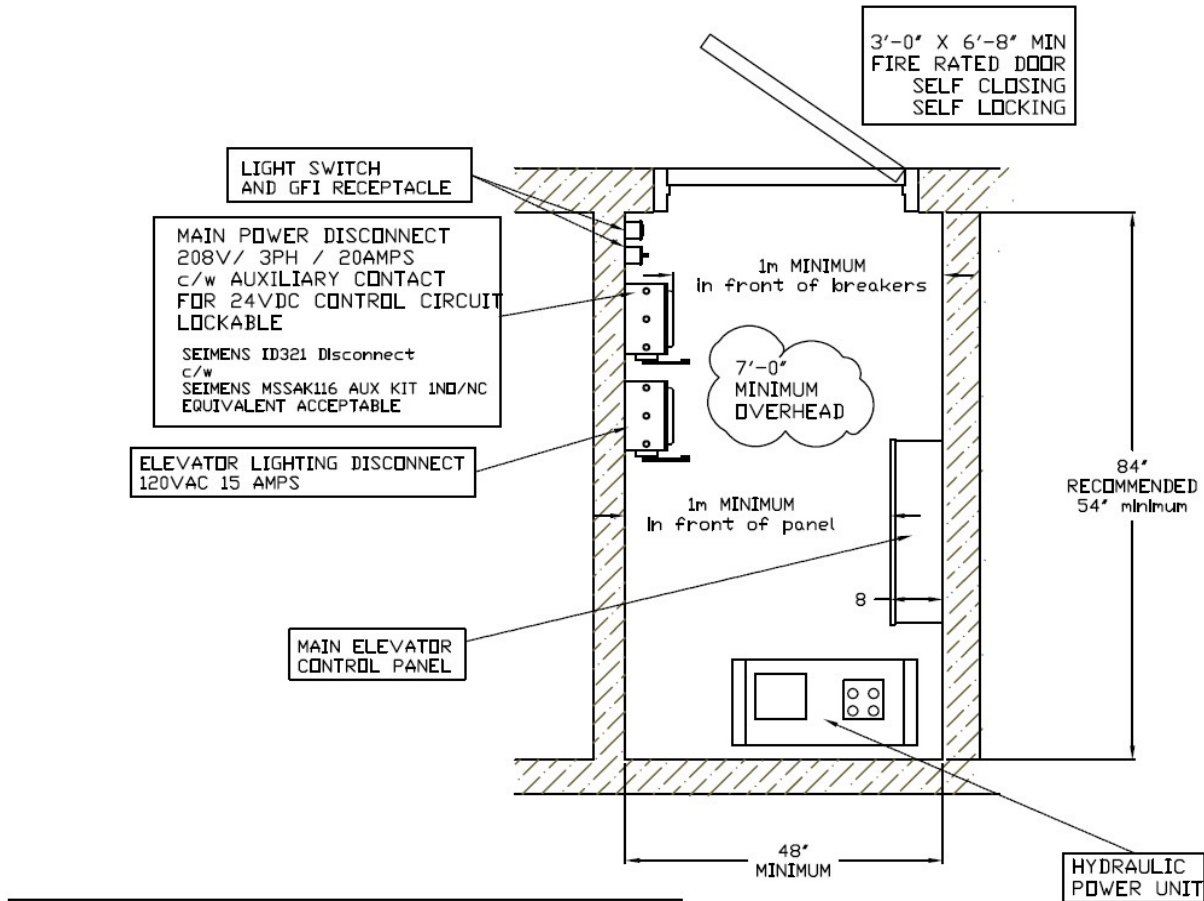

MACHINE ROOM DIMENSIONS MAY VARY
1 METRE SPACE MUST BE PROVIDED IN FRONT OF
ELECTRICAL EQUIPMENT AS PER C.E.C.

MACHINE ROOM CANNOT CONTAIN ANY MACHINERY,
CONTROL PANELS, DUCTING, WIRING OR PIPING
THAT IS NOT DIRECTLY INVOLVED WITH THE ELEVATOR

GENERAL CONTRACTOR TO PROVIDE:

- A MACHINE ROOM BUILT TO CONFORM TO THE LAYOUT DRAWINGS, AND LOCAL CODE REQUIREMENTS. IT SHALL HAVE SUITABLE ACCESS, A SELF CLOSING / SELF LOCKING DOOR, A CONVENIENCE OUTLET, LIGHTING AND LIGHT SWITCH.
- MACHINE ROOM TEMPERATURE MUST BE MAINTAINED BETWEEN 60 AND 95 DEGREES FAHRENHEIT. RELATIVE HUMIDITY NOT TO EXCEED 95%. PASSIVE VENTILATION OR HVAC MAY BE REQUIRED. ALL VENTING MUST COMPLY WITH FIRE REGULATIONS
- A 208V 3PH (STANDARD) OR 220V 1PH (OPTIONAL) OR 600V 3PH (OPTIONAL), (5HP) SERVICE, WITH NEUTRAL, TO A LOCKABLE SAFETY DISCONNECT SWITCH FUSED WITH TIME DELAY FUSES AND AUXILIARY CONTACT SHALL BE FURNISHED IN THE MACHINE ROOM TYPICAL DISCONNECT PART No. SEIMENS ID361 C/W SEIMENS MSSAK116 AUX KIT 1NO/NC CONTACTS OR EQUIV.
- A 120VAC, SINGLE PHASE, 15 AMP SERVICE TO A LOCKABLE, FUSED, DISCONNECT SWITCH OR CIRCUIT BREAKER LOCATED IN THE MACHINE ROOM SHALL BE PROVIDED FOR THE CAB LIGHTING IN ACCORDANCE WITH C.E.C..
- A SEPARATE (DEDICATED) TELEPHONE LINE TO THE MACHINE ROOM AND TIED INTO THE ELEVATOR CONTROLLER PHONE LINE MUST BE MONITORED 24HRS/7 DAYS PER WEEK BY LIVE, AUTHORIZED RESPONDER

5.1 Two Speed Hoistway/Cab Door Details

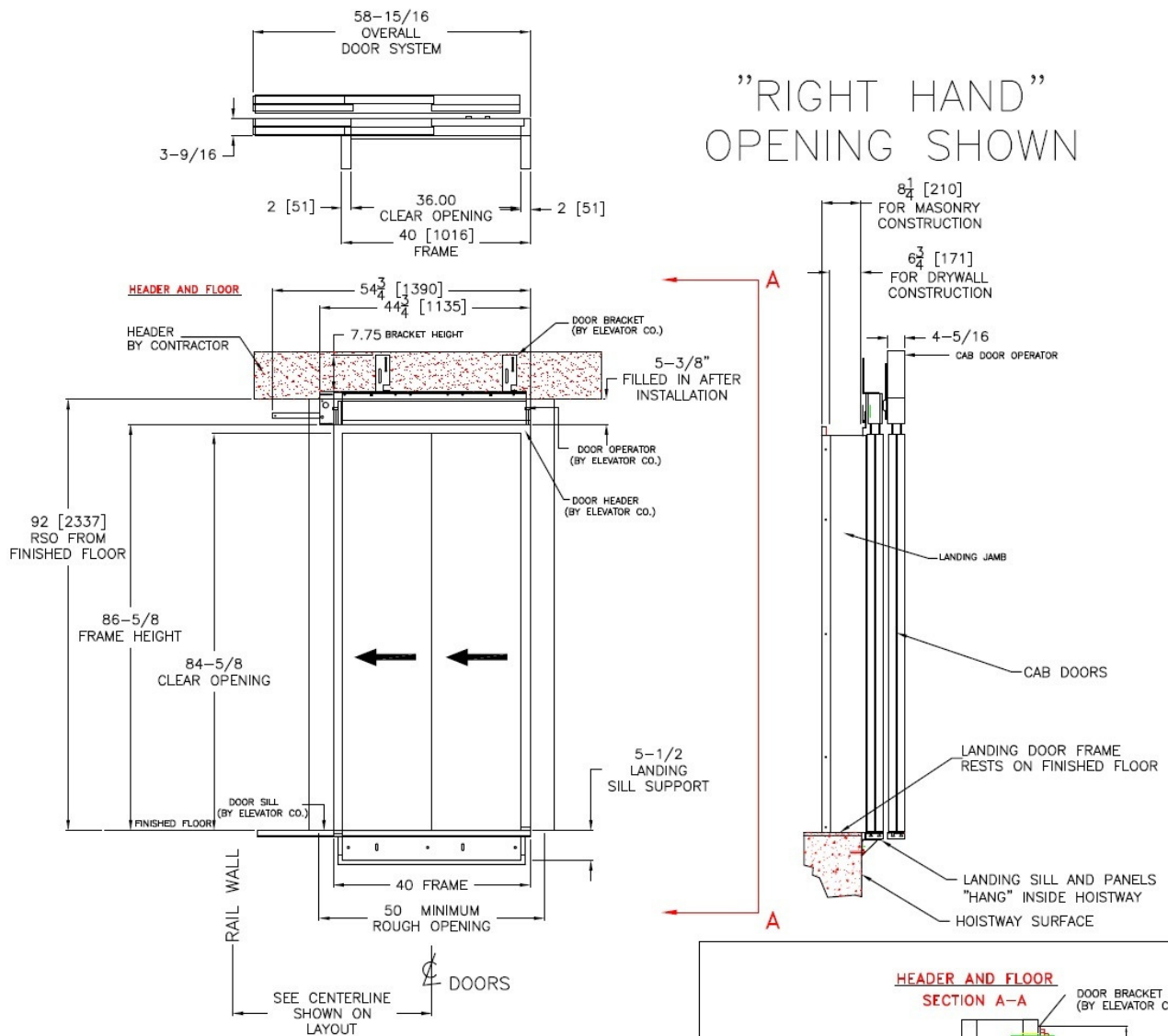

”RIGHT HAND”
OPENING SHOWN

HOSTWAY WALL/LANDING DOOR FRAME CONNECTIONS AND DOOR SYSTEM SHALL MEET ASME A17.1-2004 Section 2.11.11.8

The top and bottom of horizontally sliding doors shall be provided with a means of retaining the closed door panel in position if the primary guiding means fail, and preventing displacement of the door panel top and bottom by more than 20 mm (0.8 in.) when the door panel is subjected to a force of 5 000 N (1,125 lbf) in the direction of the hoistway applied at right angles to the panel over an area of 300 mm x 300 mm (12 in. x 12 in.) at the approximate center of the panel.

The retaining means shall also withstand, without detachment or permanent deformation, a force of 1 000 N (225 lbf) applied upward at any point along the width of the door panel and, while this force is maintained, an additional force of 1 100 N (250 lbf) applied at right angles to the door at the center of the panel. This force shall be distributed over an area of 300 mm x 300 mm (12 in. x 12 in.).

The retaining means shall not be subjected to wear or stress during normal door operation or maintenance.

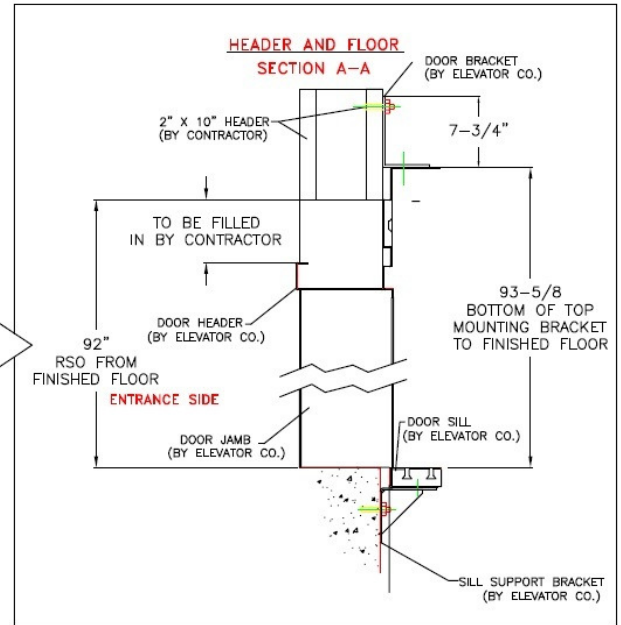

HOISTWAY WALLS AT ENTRANCES ARE TO BE BUILT AFTER DOOR SILLS AND FRAMES ARE SET IN PLACE. IF THIS IS NOT FEASIBLE, LEAVE A 50" X 92" ROUGH OPENING AT THE CENTERLINE AS SHOWN ON LAYOUT.

6.1 Standard Car Layout – Inline Configurations

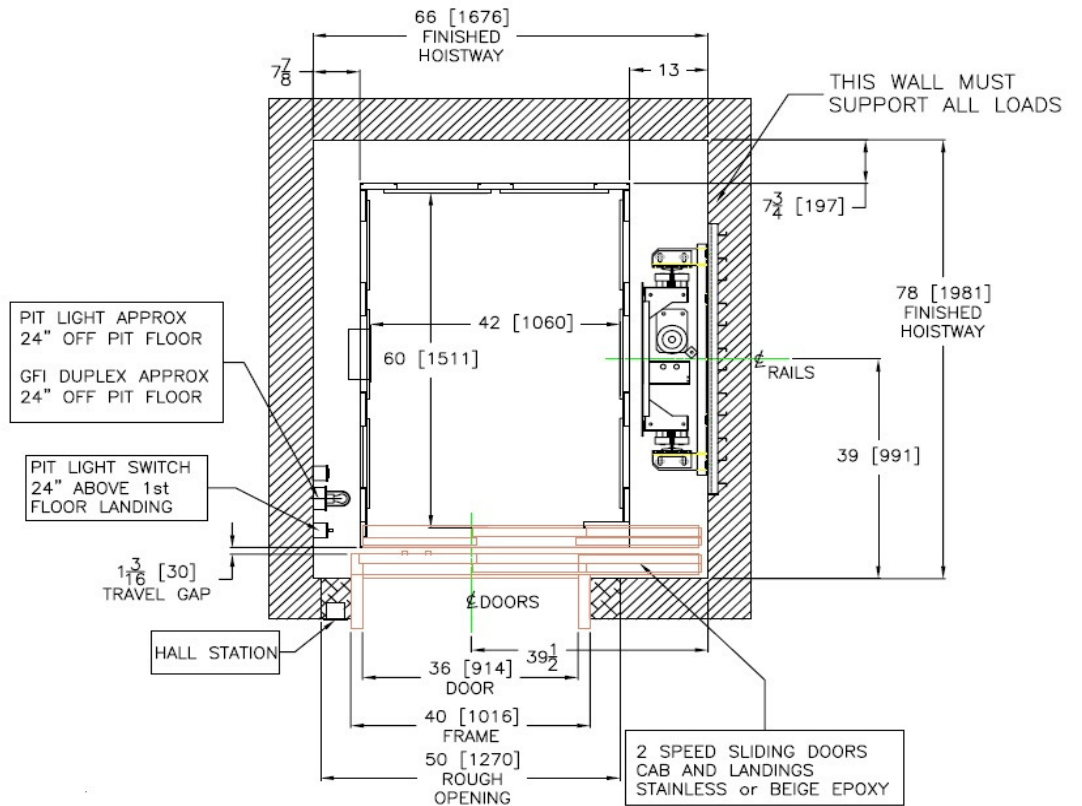
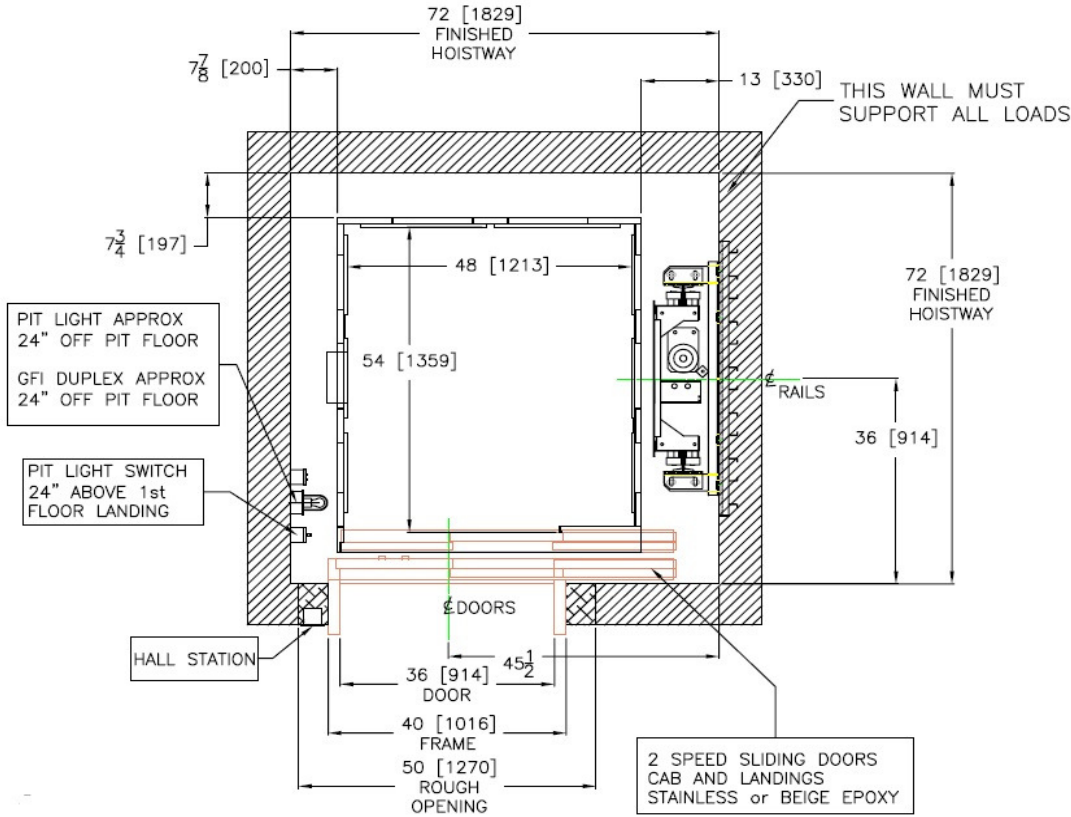

6.2 Standard Car Layout – Through Configurations

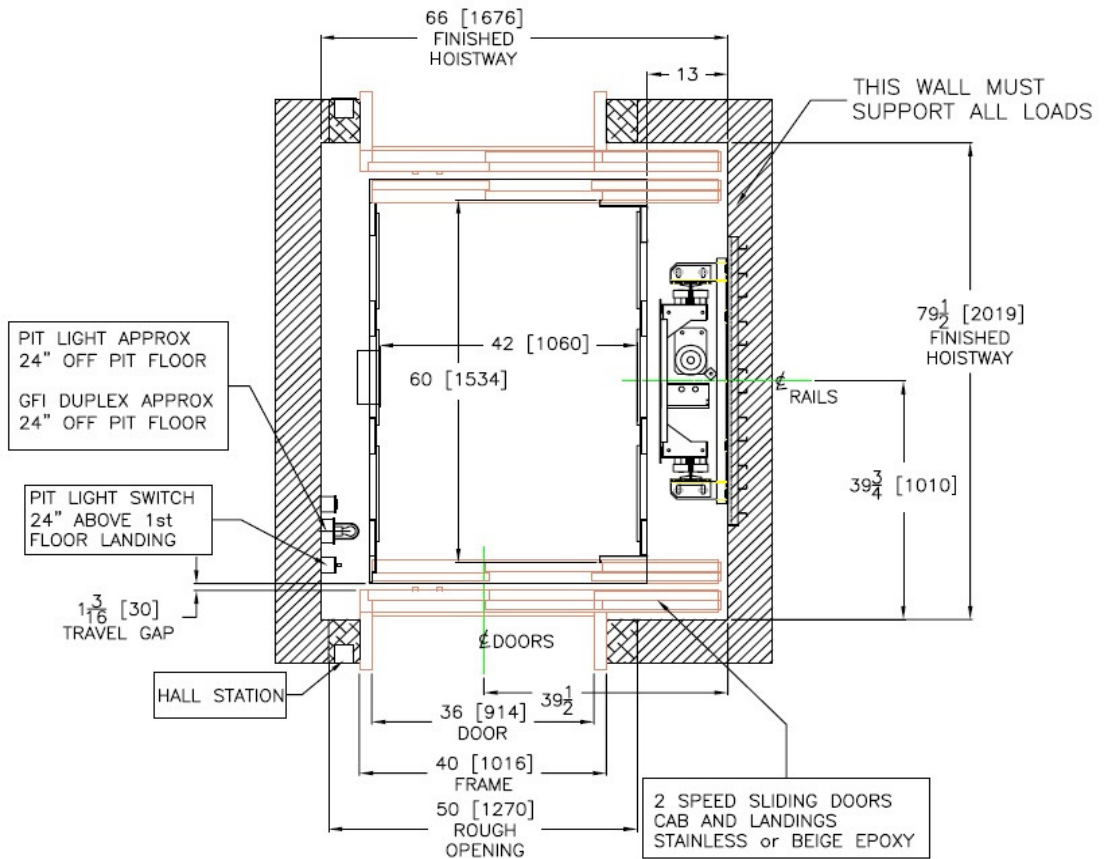
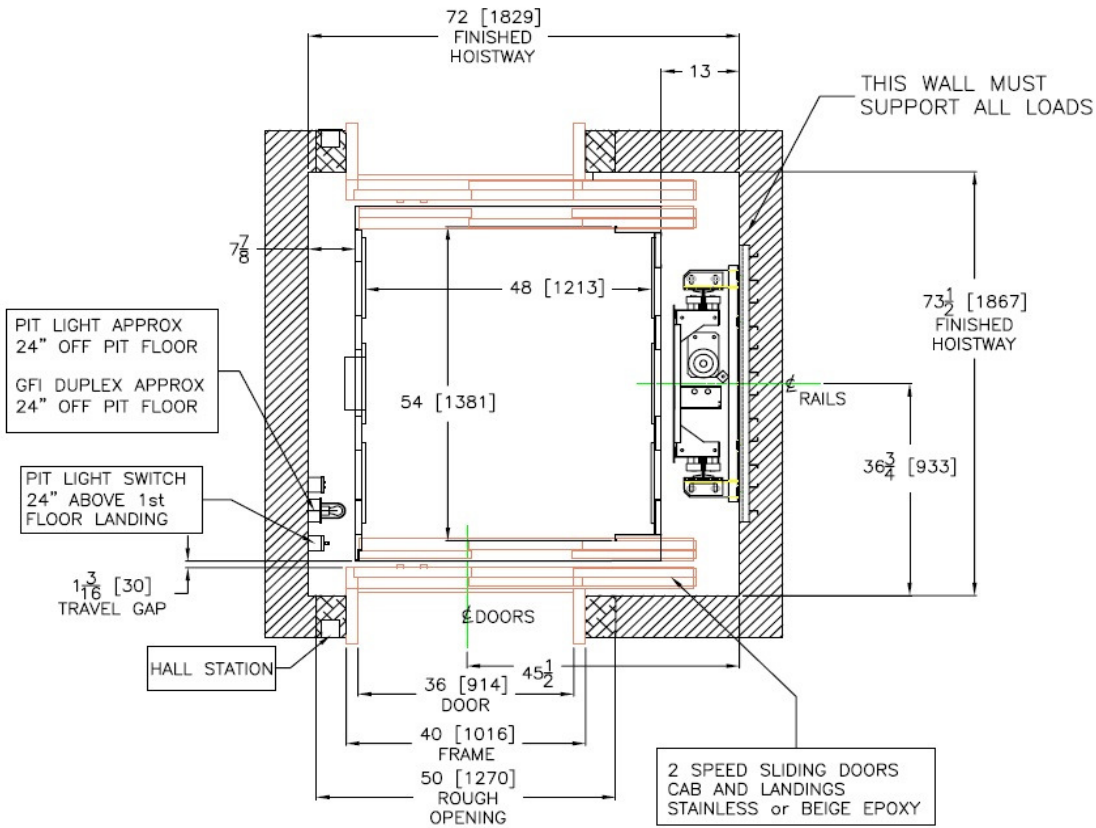

6.3 Standard Car Layout – 90 Degree Configuration

