

STRATUS ELEVATOR

Contemporary
Elegance



RESIDENTIAL

trustram.com
1-800-563-4382



VALUE WITHOUT COMPROMISE

The era of complex and expensive home elevators is over. In its place is the Stratus, a fresh take on what a home elevator can be.



Rising above the status quo, the Stratus marries value with performance, without cutting corners. Available in three standard-format sizes, the Stratus is specifically designed for two floors of travel with intermediate stops, significantly reducing on-site installation time and cost. Perfect for new homes and retrofits alike, the Stratus seamlessly integrates into your two-storey space.

Once installed, the Stratus boasts engineered polymers on all guides in addition to an all-electric drive system. The result? A dependable and comfortable ride that lasts for years.



trustram.com
1-800-563-4382



THE HIGHLIGHTS

IDEAL FOR:



Private Residence



Indoor Use



Multiple Entry/Exit

MAX CAPACITY:

800 LBS

MAX TRAVEL SPEED:

20 FT/MIN

MAX TRAVEL DISTANCE:

14 FT

ENTRANCE/EXIT POINTS:

In-out same side, Straight through, or Adjacent

MAX CAR SIZE:

W40" x L60"



KEY FEATURES

Engineered Polymers **RA**

With advanced engineered polymers on all guides the Stratus eliminates the need for grease and keeps rides smooth and quiet for years to come.

Automatic Call buttons **RA**

The Stratus can be called with the single push of a button for total rider convenience.

Tailored Finishes

Choose from multiple interior finishes and door styles to complement your home.

Soft Start/Stop **RA**

Thoughtful engineering means every ride on a RAM product begins and ends with comfort in mind.

All-Electric Drive System **RA**

RAM's field-proven electric drive system is reliable, powerful and whisper-quiet. Plus, no hydraulic fluid = no harsh smells.

Machine-Room Less (MRL) Design **RA**

While other elevators may need a separate room for essential machinery, every RAM product is compact and self-contained, saving you space, time and money.

RA = RAM Advantage, an essential feature found in all of our products.

trustram.com
1-800-563-4382

Low Overhead Clearance **RA**

Smart space design delivers the most space-efficient MRL product on the market. All drive components mount directly to the top of the RAM rigid guiderail frame fitting into a standard 92" top-floor ceiling height

No Pit Required **RA**

Choose a pitless build with a 2" ramp, ideal for existing spaces, or a 2" pit for flush access.

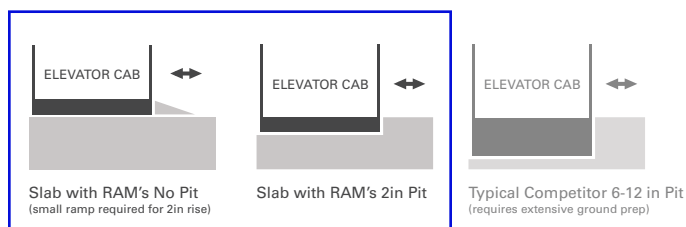

The Stratus Range

Pick from three standard car sizes and three travel heights to best meet your needs.

Some customization is also possible, as needed.

	Car Inside Dimensions			Shaft Dimensions	
	Width (W)	Depth (D)	Height (C)	Depth (SD)	Length (SL)
Small	36"	48"	84"	50.5"	53.5"
Medium	40"	54"	84"	54.5"	59.5"
Large	40"	60"	84"	54.5"	65.5"

Max Travel (T)	Min Overhead Clearance*	Tower Height (TH)
9'	92"	13'
11'	92"	15'
14'	92"	18'

* Overhead Clearance is measured from the floor of the top landing.
 The travel for each size is infinitely adjustable up to the maximum travel height

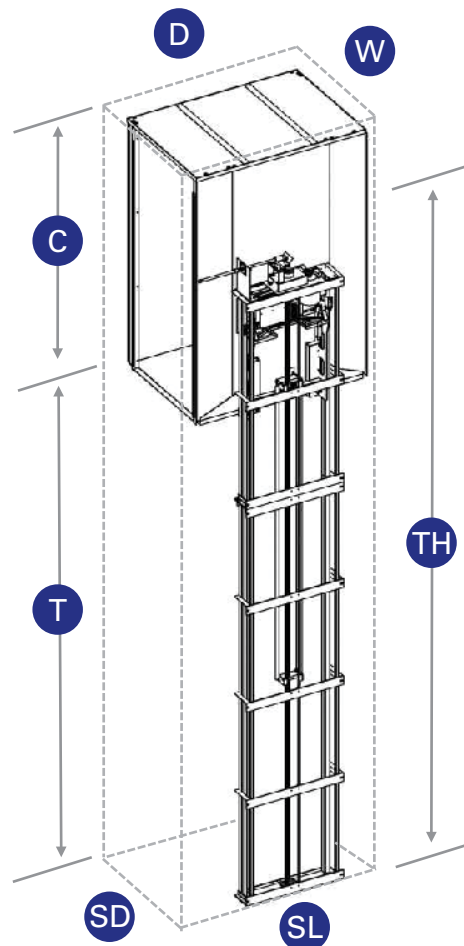



trustram.com
1-800-563-4382



LEADING-EDGE QUALITY AND DEPENDABILITY

Superior Reliability

Three tiers of emergency auxiliary power are available for every RAM product:

1. Emergency manual crank & battery backup for car lighting and controls (Standard)
2. Battery backup lowering will run the motor in the down direction during a power outage (Optional)
3. Full battery 40-cycle backup that will run the motor with full load for 40 cycles during a power outage (Optional)

Maintenance

Total cost of ownership is critical. By design, RAM has one of the lowest maintenance offerings that still ensures safe operation during the entire lifecycle. We know that low maintenance with a focus on safety is the key to peace of mind.

Power Requirements

220 VAC, 1PH, 20A MAIN Power

110 VAC, 1PH, 15A Shaft Lights & Plugs

Warranty

The RAM Residential Stratus is covered by a 2 year warranty. Extended Warranties Available, Contact RAM for details.

Code Relevance

Designed to meet ASME A17.1/CSA B44 safety standards when properly equipped.

While RAM residential elevators meet national standards, it is imperative to check State/Provincial and Local code requirements before installing to ensure compliance. All State/ Provincial and Local compliance is the responsibility of the purchaser. Some states may require fees for site preparation and permits.



trustram.com
1-800-563-4382

